

Profil	Vikt (Kg / m)	A (mm)	B (mm)	C (mm)	D (mm)
A 45	22,10	55,00	125,00	45,00	24,00
A 55	31,80	65,00	150,00	55,00	31,00
A 65	43,10	75,00	175,00	65,00	38,00
A 75	56,20	85,00	200,00	75,00	45,00
A 100	74,30	95,00	200,00	100,00	60,00
A 120	100,00	105,00	220,00	120,00	72,00
A 150	150,30	150,00	220,00	150,00	80,00

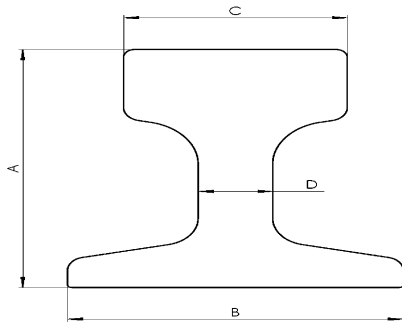

Kranräl special	Vikt (Kg / m)	A (mm)	B (mm)	C (mm)	D (mm)
MRS 73	73,63	157,00	146,00	70,00	32,00
MR 7/5A	77,00	100,00	200,00	100,00	60,00
MRS 86	85,50	102,00	165,00	102,00	80,30
MRS 87A (PRI 85R)	86,80	152,40	152,40	101,60	34,93
MRS 125	125,00	180,00	180,00	120,00	40,00
MRS 221	221,40	160,00	220,00	220,00	145,00

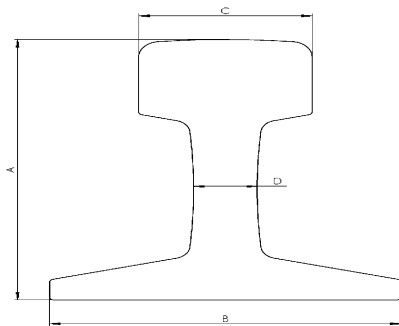

Amerikanska profiler	Vikt (Kg / m)	A (mm)	B (mm)	C (mm)	D (mm)
MRS 51 / CR 104	51,59	127,00	127,00	63,50	25,40
MRS 52 / CR 105	52,09	131,76	131,76	65,09	23,81
MRS 67 / CR 135	66,97	146,05	131,76	87,31	31,75
MRS 85 / CR 171	84,83	152,40	152,40	109,22	31,75
MRS 87B / CR 175	86,80	152,40	152,40	107,95	38,10

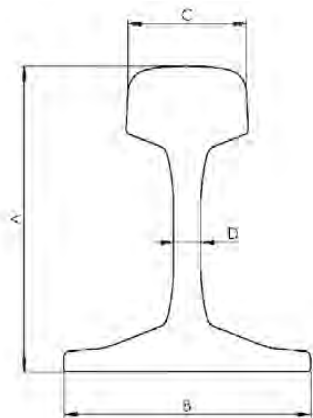

Profil	Vikt	A	B	C	D
Nya:	Kg / m	mm	mm	mm	mm
S 30	30,03	107,95	107,95	60,33	12,30
S 33	33,47	134,00	105,00	58,00	11,00
S 41	40,95	138,00	125,00	67,00	12,00
D.S.B.V ^{1.)}	45,46	141,00	126,00	69,30	13,76
S 49	49,43	149,00	125,00	67,00	14,00
50 E3 (BV 50) ^{1.)}	50,02	155,00	133,00	70,00	14,00
54 E2 (UIC 54 E)	53,81	161,00	125,00	67,00	16,00
54 E3 (S 54)	54,40	154,00	125,00	67,00	16,00
54 E1 (UIC 54)	54,43	159,00	140,00	70,00	16,00
60 E1 (UIC 60) ^{1.)}	60,34	172,00	150,00	72,00	16,50
^{1.)} Finns även som begagnade					
Endast begagnade:					
27 kg	27,80	108,00	102,00	57,00	11,00
30 kg	30,14	125,50	106,00	56,00	11,00
SJ 32	32,00	123,00	123,00	60,00	11,00
SJ 34	34,50	126,50	122,00	64,00	13,00
D.S.B 37	36,96	128,00	115,00	58,00	12,50
N.S.B 40	39,80	139,00	110,00	60,00	13,00
SJ 41	41,18	133,00	133,00	69,00	13,00
SJ 43	43,20	133,00	133,00	69,00	14,00
SJ 50	50,00	155,40	133,00	70,00	14,00